

Scelta indicativa Oxiget
Indicative selection Oxiget
Choix indicatif de l'Oxiget

$$P = 0,03 \times V$$

P = Potenza del motore
Motor rating [kW]
Puissance moteur

V = Volume liquido vasca
Volume of liquid sump [m³]
Volume liquide bassin

Q = Aria aspirata - Air capacity - Air aspiré - [l/s]
Z = Battente - Submergence - Charge d'eau - [m]
QO₂ = Ossigeno aspirato - Oxygen in air capacity - Oxygène aspiré dans l'air - [kg/h]
O₂ = Ossigeno reso - Oxygen transfer - Oxygène absorbé - [kg/h]

Curve per liquidi aventi densità 1 - viscosità 1 mm²/s - alla temperatura di 20° C.
Curves established for liquid density 1 - viscosity 1 mm²/s - temperature 20° C.
Courbes établies pour liquides densité 1 - viscosité 1 mm²/s - température 20° C.

Complesso Pompa + Eiettore Assembly Pump + Ejector Groupe Pompe + Ejecteur	COMPOSIZIONE - COMPOSITION - COMPOSITION													
	Elettropompa - Electric Pump - Electropompe						Eiettore				Accessori - Accessories - Accessoires			
	Pompa Tipo Pump Type Pompe Type	Mandata Discharge Reboulement	Potenza motore Motor rating Puissance mot.	Avvolgimenti Windings Bobinages	Absorbimento Absorption Intensité	Giri/min RPM T/min	Avviamento Startup Demarrage	Eiettore Tipo Ejector Type Ejecteur Type	Tubo Aspirazione Suction Pipe Tube d'Aspiration	Filtro Filter Filtre	Portagomma Hose Connection Porte Tuyau	Telaio Frame Chassis		
OXIGET 2 - 80	PTS 2,2 - 80	80	2,2	230-400	5,3	1420	λ	80 - 55	TA 80	F 80	PGF 80	TSO 80		
OXIGET 3 - 80	PTS 3 - 80		3		6,8	1420	λ							
OXIGET 4 - 80	PTS 4 - 80		4		9,1	1405	Δ λ-Δ							
OXIGET 5,5 - 100	PTS 5,5 - 100	100	5,5	400-690	12,5	1430	Δ λ-Δ	100 - 63	TA 100	F 100	PGF 100	TSO 100		
OXIGET 7,5 - 100	PTS 7,5 - 100		7,5		15,8	1440	Δ λ-Δ							
OXIGET 9 - 100	PTS 9 - 100		9		19	1440	Δ λ-Δ							
OXIGET 11 - 150	PTS 11 - 150	150	11	400-690	23,5	1450	Δ λ-Δ	150 - 95	TA 150	F 150	PGF 150	TSO 150		
OXIGET 15 - 150	PTS 15 - 150		15		30	1450	Δ λ-Δ							

Forma del getto
Jet shape
Forme du jet

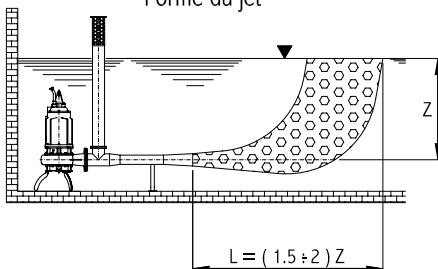

INSTALLAZIONI POSSIBILI - POSSIBLE INSTALLATIONS - INSTALLATIONS POSSIBLES

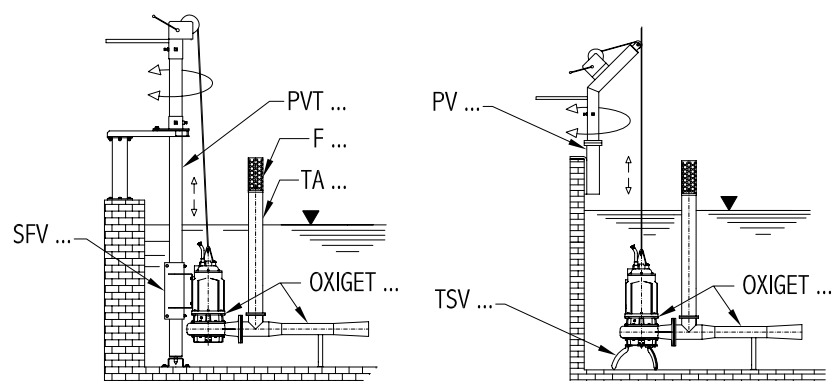

Per le caratteristiche delle elettropompe PTS consultare le pagine della "serie PTS" del presente catalogo.
For technical specification of the PTS electric pumps please see the "PTS series" pages of this catalogue.
Pour les détails des électropompes PTS, voir les pages des "series PTS" de ce catalogue.

OXIGET 2 - 80
OXIGET 3 - 80
OXIGET 4 - 80

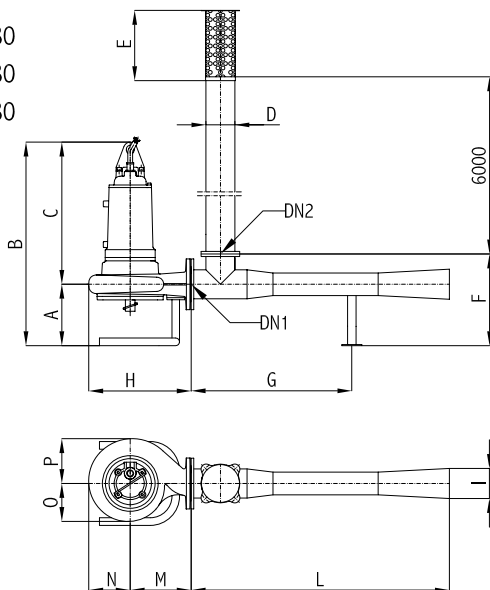

OXIGET 5,5 - 100
OXIGET 7,5 - 100
OXIGET 9 - 100
OXIGET 11 - 150
OXIGET 15 - 150

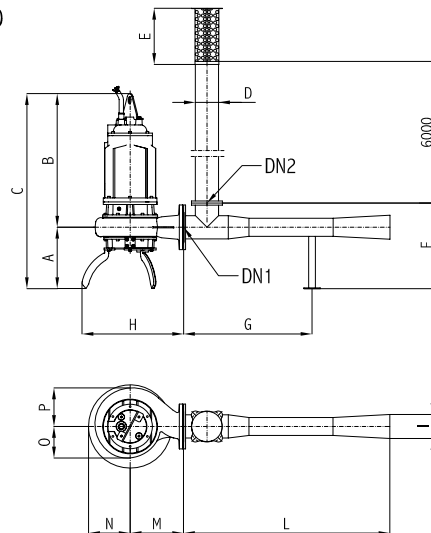

DIMENSIONI INGOMBRO [mm] - OVERALL DIMENSIONS [mm] - DIMENSIONS [mm]

Oxiget Tipo Oxiget Type Oxiget Type	DN1	DN2	A	B	C	D	E	F	G	H	I	L	M	N	O	P
OXIGET 2 - 80	80	80	240	564	804	88,9	200	360	632	402	118	1016	240	162	149	176
OXIGET 3 - 80				570	810											
OXIGET 4 - 80																
OXIGET 5,5 - 100	100	100	302	659	961	114	260	421	500	118	1016	263	205	189	190	
OXIGET 7,5 - 100																
OXIGET 9 - 100																
OXIGET 11 - 150	150	150	342	805	1147	168	395	491	943	605	202	1592	342	226	196	256
OXIGET 15 - 150																

ACCESSORI - ACCESSORIES - ACCESSOIRES

Oxiget Tipo Oxiget Type Oxiget Type	Telaio di sostegno Frame Châssis de soutien	Attacco palo Motor bracket Console du mot.	Paranco con verricello e tubo guida Hoist winch and rail pipe Trebail poulie et barre de guidage	Paranco con verricello Hoist and winch Trebail et poulie	Portagomma con flangia Hose connection with flange Porte-tuyau avec bride	Tubo aspirazione Suction pipe Tube d'aspiration	Filtro di aspiraz. Aspiration filter Filtre d'aspiration
OXIGET 2 - 80	TSV 80	SFV 80	PVT 80 /..	PV 80	PGF 80	TA 80	F 80
OXIGET 3 - 80							
OXIGET 4 - 80							
OXIGET 5,5 - 100	TSV 100	SFV 100	PVT 100 /..	PV 100	PGF 100	TA 100	F 100
OXIGET 7,5 - 100							
OXIGET 9 - 100							
OXIGET 11 - 150	TSV 150	SFV 150	PVT 150 /..	PV 150	PGF150	TA 150	F 150
OXIGET 15 - 150							